



Pentair Water

Fleck 4650

Service Manual

TABLE OF CONTENTS

JOB SPECIFICATION SHEET	1
INSTALLATION AND START-UP PROCEDURE.....	1
CONTROL VALVE DRIVE ASSEMBLY	2
CONTROL DRIVE ASSEMBLY FOR CLOCK	3
BYPASS VALVE ASSEMBLY	4
WATER CONDITIONER FLOW DIAGRAMS	5
SERVICE INSTRUCTIONS	7
TROUBLESHOOTING	9
SERVICE ASSEMBLY	10

JOB SPECIFICATION SHEET

Job Number: _____

Model Number: _____

Water Test: _____

Capacity Per Unit: _____ Max. _____ Per Regeneration

Mineral Tank Size Diameter: _____ Height: _____

Brine Tank Size and Salt Setting per Regeneration: _____

1. Type of Timer:

- A. "L"
- B. 7 Day
- C. 12 Day

2. Day/Time of Regeneration: _____

3. Drain Line Flow Control: _____ gpm

4. Brine Refill Rate: _____ gpm

5. Injector Size#: _____



INSTALLATION AND START-UP PROCEDURE

The water softener should be installed with the inlet, outlet and drain connections made in accordance with manufacturer's recommendations and to meet applicable plumbing codes.

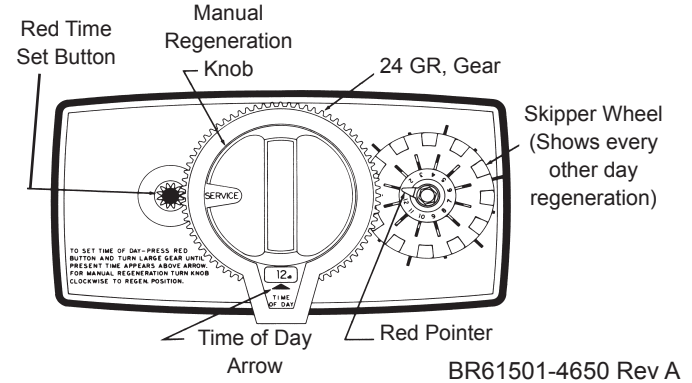
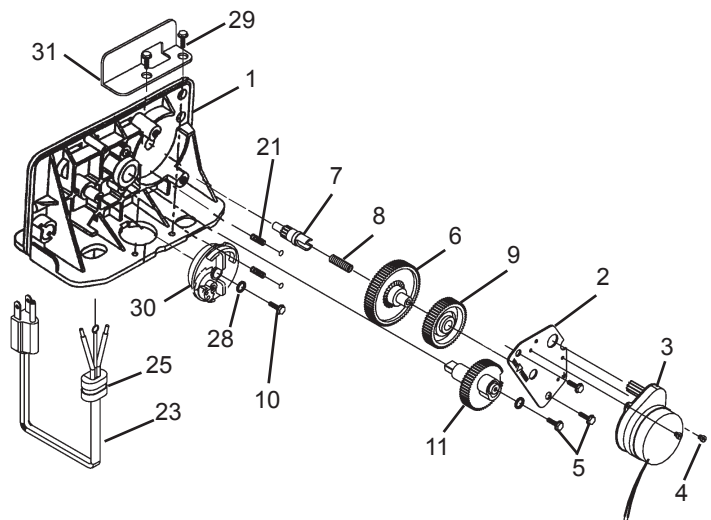
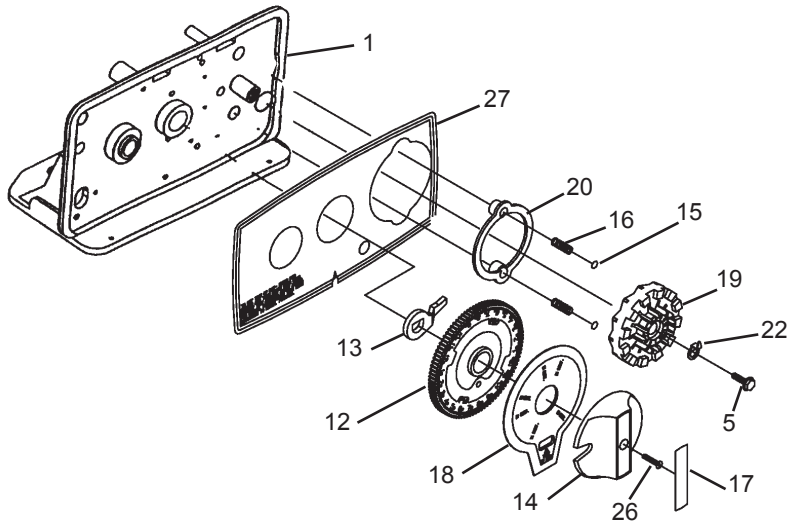

Figure 1

1. Manually index the softener control into the service position and let water flow into the resin tank. When the water flow stops, open a softened water tap until all air is released from the lines, then close the tap.

Note: The various regeneration positions may be dialed manually by turning the knob on the front of the control until the indicator shows that the softener is in the desired position.
2. Manually index the control to the backwash position and allow water to flow at the drain for 3 or 4 minutes.
3. Remove back cover plate.
4. Make sure that the salt dosage is set as recommended by the manufacturer. Manually index the control to the brine fill position and allow the brine tank to fill to the top of the air check.
5. Manually index the control to the brine draw position and allow the control to draw water from the brine tank until it stops.
6. Plug in the electrical cord and look in the sight hole in the back of the motor to see that it is running. Set the days that regeneration is to occur by sliding tabs on skipper wheel outward to expose trip fingers. Each tab is one day. Finger at red pointer is tonight. Moving clockwise from red pointer, extend or retract fingers to obtain the desired regeneration schedule.
7. Manually advance the control to the beginning of the brine fill position; and allow the control to return to the service position automatically.
8. Fill the brine tank with salt.
9. Replace back cover on the control.
10. Make sure that any bypass valving is left in the normal service position.

CONTROL VALVE DRIVE ASSEMBLY



BR61501-4650 Rev A

Item No.	QTY	Part No.	Description
1.....	1	15494-01.....	"L" Housing - w/Pin
2.....	1	13175.....	Motor Mounting Plate
3.....	1	18743-1.....	Motor - 120V, 60 Hz, 1/30 rpm
	1	18752-1.....	Motor - 100V, 50 Hz, 1/30 rpm
	1	18824-1.....	Motor - 23V, 50 Hz, 1/30 rpm
	1	18826-1.....	Motor - 24V, 50 Hz, 1/30 rpm
	1	19659-1.....	Motor - 24V, 60 Hz, 1/30 rpm
	1	19660-1.....	Motor - 230V, 60 Hz, 1/30 rpm
4.....	3	11384	Screw - Motor Mtg. & Ground Wire
5.....	3	13296.....	Screw - Component Mounting
6.....	1	13017.....	Idler Gear
7.....	1	13018.....	Idler Pinion
8.....	1	13312.....	Spring - Idler
9.....	1	13164.....	Drive Gear
10.....	1	40214.....	Screw - Brine Cam
11.....	1	13170.....	Main Gear & Shaft
12.....	1	19205-01.....	24-Hour Gear Assembly, Silver
13.....	1	13011.....	Cycle Actuator Gear
14.....	1	14177.....	Knob - Manual Regeneration
15.....	4	13300.....	Ball - 1/4" Dia.

Item No.	QTY	Part No.	Description
16.....	2	13311.....	Spring - Detent - Skipper Wheel
17.....	1	14207.....	Knob Label - Silver
18.....	1	14176.....	Valve Position Dial - Standard
19.....	1	14381.....	Skipper Wheel Assembly - 12 Day
	1	14860.....	Skipper Wheel Assembly - 7 Day
20.....	1	13864.....	Skipper Wheel Ring
21.....	2	14457.....	Spring - Detent - Main Gear
22.....	1	13014.....	Regeneration Pointer
23.....	1	11842.....	Electrical Cord - Standard
24.....	2	12681.....	Wire Connector (Not Shown)
25.....	1	13547.....	Strain Relief
26.....	1	15151.....	Screw - Knob
27.....	1	14331.....	Front Label - Silver on Black
28.....	1	12037.....	Washer
29.....	2	12473.....	Screw-Drive Mounting
30.....	1	60514.....	Brine Cam Assembly, 3-18
	1	60514-01.....	Brine Cam Assembly, 6-36
	1	60514-02.....	Brine Cam Assembly, Minutes
31.....	1	40327.....	Support Bracket (Hot water Only)

CONTROL DRIVE ASSEMBLY FOR CLOCK

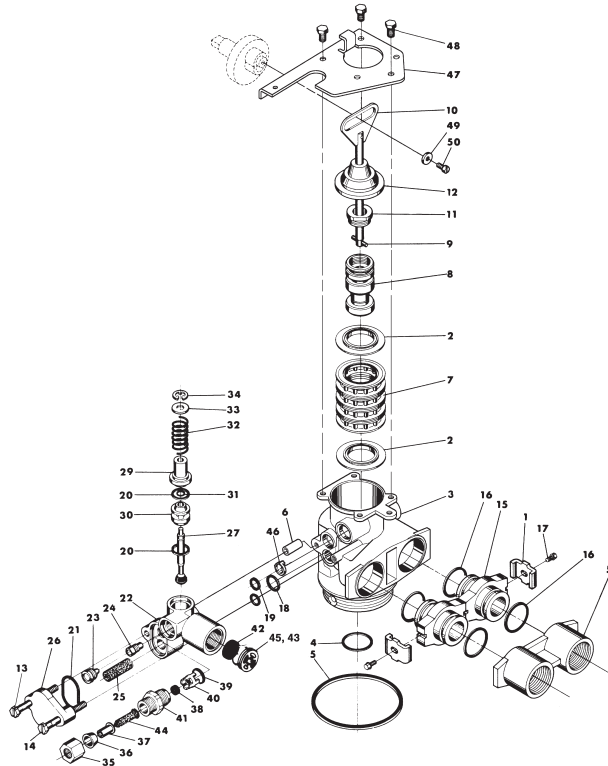

BR61500-4650 Rev A

Item No.	QTY	Part No.	Description	Item No.	QTY	Part No.	Description
1	2	13255	Adapter Clip	24	1	10226-xx	Injector Throat - Specify Size - Hot Water
2	5	13242	Seal				
	5	17772	Seal, 4650, HW, Chloramine resistant	1	10914-xx	Injector Throat - Specify Size - Cold Water	
3	1	40319	Valve Body	25	1	10227	Injector Screen
4	1	13304	O-ring - Distributor Tube - 1"	26	1	13166	Injector Cover
	1	13304-01	O-ring, -121, 560CD, HW	27	1	13172-03	Brine Valve Stem Assembly - Hot Water
5	1	10381	O-ring - Top of Tank				
	1	10381-01	O-ring, -231, 560CD, HW	1	13172-02	Brine Valve Stem Assembly - Cold Water	
6	1	13361	Stand-Off	29	1	13165	Brine Valve Cap
7	4	14241-01	Spacer - Hot Water	30	1	13167	Brine Valve Spacer
	4	14241	Spacer - Cold Water	31	1	12550-01	Quad Ring - Hot Water
8	1	13247	Piston - Standard				
9	1	10696	Piston Pin	1	12550	Quad Ring - Cold Water	
10	1	13001	Piston Rod Assembly	32	1	11973	Spring - Brine Valve
11	1	12953	Piston Retainer	33	1	16098	Washer - Brine Valve
12	1	61411	End Plug Assembly, Brass - Hot Water	34	1	11981-01	Retaining Ring
	1	13446	End Plug Assembly, Std., White - Cold Water	35	1	10329	BLFC Fitting Nut
13	1	13387	Screw - Injector Mounting	36	1	10330	BLFC Ferrule
14	1	13315	Screw - Injector Mounting	37	1	10332	BLFC Tube Insert
15	2	19228	Adapter Coupling	38	1		BLFC Button - Specify Size
16	4	13305	O-ring - Adapter Coupling	39	1	12977	O-ring - BLFC
17	2-4	13314	Screw - Adapter Coupling				
18	1	12638	O-ring - Drain	1	12977-01	O-ring, -015, 560CD, HW	
	1	12638-01	O-ring, -013, 560CD, Injector, HW	40	1	13245	BLFC Button Retainer
19	2	13301	O-ring - Injector	41	1	13244	BLFC Fitting
	2	13301-01	O-ring, -011, 560CD, HW	42	1		DLFC Button - Specify Size
20	2	13302-01	O-ring - Brine Spacer - Hot Water	43	1	13173	DLFC Button Retainer
	2	13302	O-ring - Brine Spacer - Cold Water	44	1	12767	Screen - Brine Valve
21	1	13303	O-ring - Injector Cover	45	1	15348	O-ring - DLFC (not shown)
	1	13303-01	O-ring, -021, 560CD, HW	46	1	13497	Air Dispenser
22	1	13163	Injector Body	47	1	13546	End Plug Retainer
23	1	10225-xx	Injector Nozzle - Hot Water				
	1	10913-xx	Injector Nozzle - Cold Water	1	40324	End Plug Retainer, Hot Water	
				48	3	12112	Screw
				49	1	13363	Washer
				50	1	13296	Screw
				51	1	13398	Yoke, Brass, 1" NPT
					1	13708	Yoke, Brass, 3/4" NPT

BYPASS VALVE ASSEMBLY

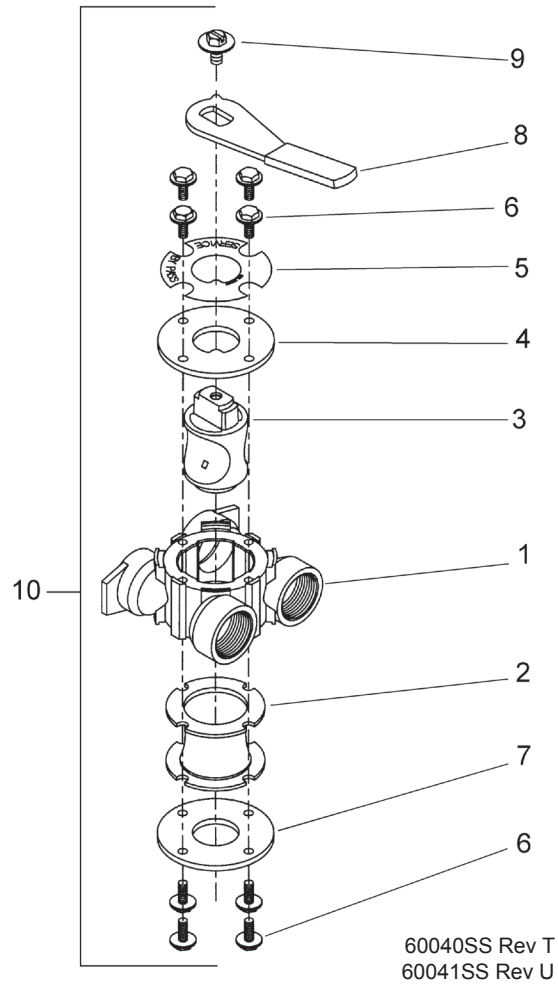

Item No.	QTY	Part No.	Description
1.....	1	40614.....	Bypass Body, 3/4"
	 40634.....	Bypass Body, 1", SS
2.....	1	14105.....	Seal, Bypass, 560CD
3.....	1	11972.....	Plug, Bypass
4.....	1	11978.....	Side Cover
5.....	1	13604-03.....	Label
6.....	8	15727.....	Screw
7.....	1	11986.....	Side Cover
8.....	1	11979.....	Lever, Bypass
9.....	1	11989.....	Screw, Hex Head, 1/4-14
10.....	1	60040SS.....	Bypass Valve, 5600, 3/4" NPT Blk Grip Lever, SS
	 60041SS.....	Bypass Valve, 5600, 1" NPT Blk Grip Lever, SS

WATER CONDITIONER FLOW DIAGRAMS

1 Service Position

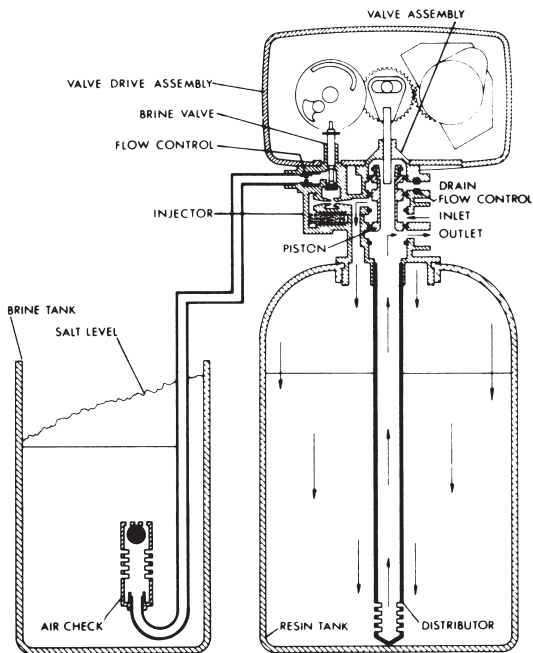

Hard water enters the unit at the valve inlet - flows around the lower piston groove - thru the passage to the top of tank - down thru the resin and enters the distributor as conditioned water. The conditioned water flows up thru the center tube to the valve outlet.

2 Preliminary Rinse Position (5 Minutes)

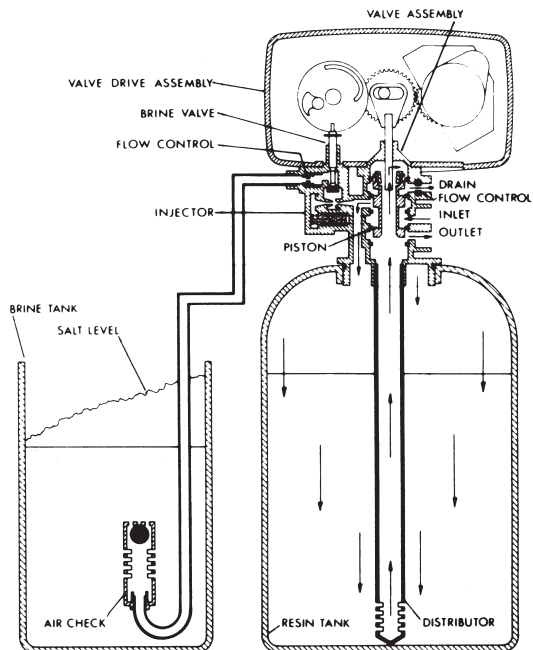

Hard water enters the unit at the valve inlet - flows around the lower piston groove - down thru the top of tank passage - downward thru the resin - up the distributor tube - thru the center hole in the piston - over the top edge of the piston and out the drain line.

3 Backwash Position (10 Minutes)

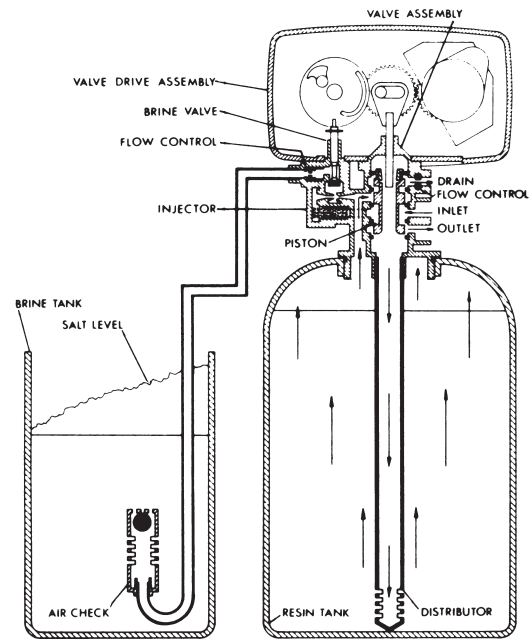

Hard water enters the unit at the valve inlet - flows around the lower piston groove and lower piston land - down thru the center tube and out the distributor - up thru the resin - thru the top of tank passage - around the upper piston groove and out the drain line.

4 Brine Position (First Portion of 50 Minute Fixed Cycle)

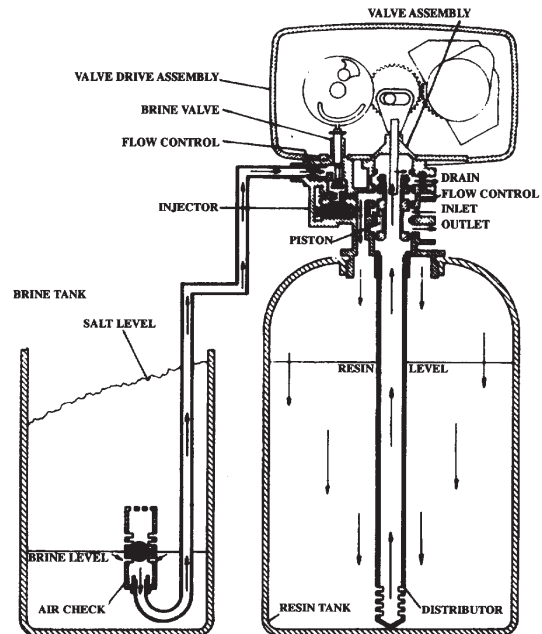

Hard water enters the unit at the valve inlet - flows around the lower piston groove - thru the injector nozzle and orifice to draw brine from the brine tank. The brine flows down thru the resin - into the distributor - up thru the center tube - thru the center hole in the piston and out the drain line.

WATER CONDITIONER FLOW DIAGRAMS *continued*

5 Slow Rinse Position (Last Portion of 50 Minute Fixed Cycle)

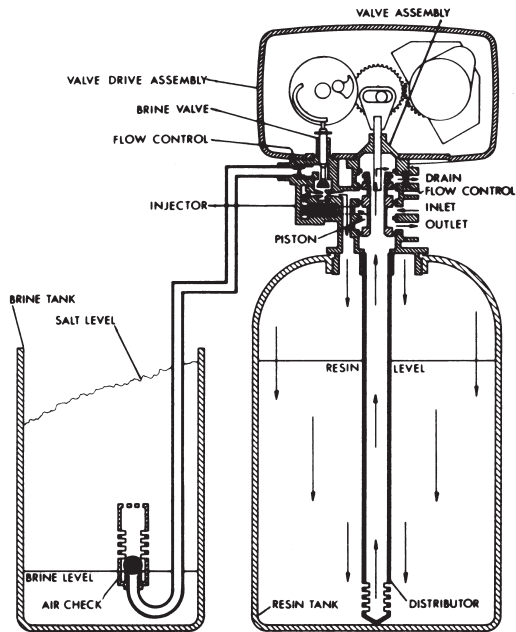

After all the brine has been drawn from the brine tank, hard water continues to enter thru the valve inlet - flows around the lower piston groove - thru the nozzle and orifice - down thru the resin and into the distributor - up thru the center tube - thru the center hole in the piston and out the drain line.

7 Settling Rinse Position (5 Minutes)

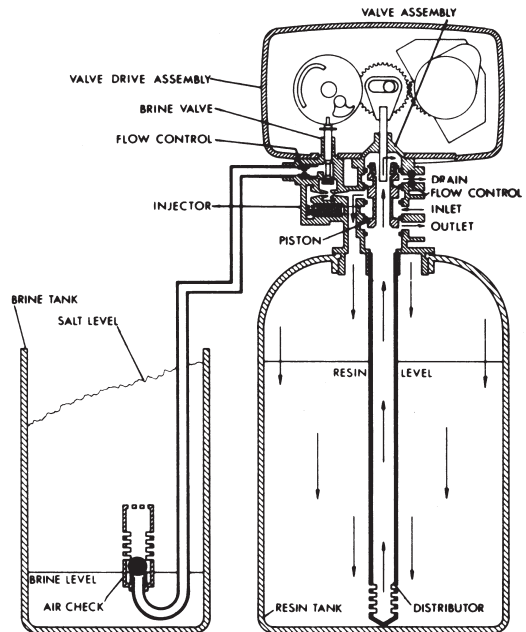

Hard water enters the unit at the valve inlet - flows around the lower piston groove - down thru the top of tank passage - downward thru the resin - up the distributor tube - thru the center hole in the piston - over the top edge of the piston and out the drain line.

6 Second Backwash Position (10 Minutes)

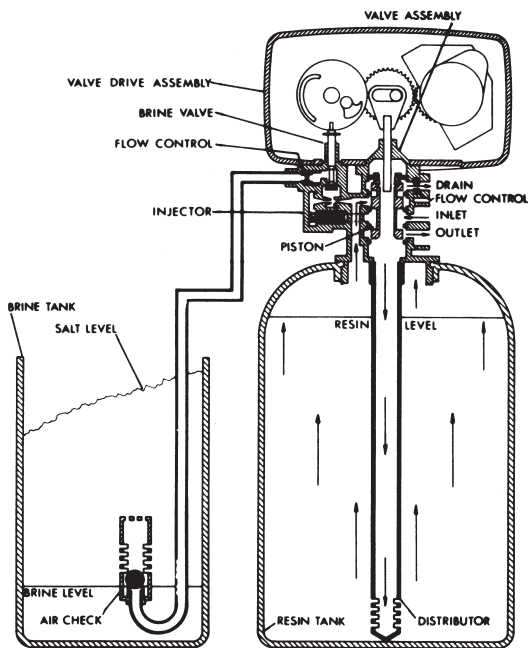

Hard water enters the unit at the valve inlet - flows around the lower piston groove and lower piston land - down thru the center tube and out the distributor - up thru the resin - thru the top of tank passage - around the upper piston groove and out the drain line.

8 Brine Tank Fill Position (4 to 24 Minutes Adjustable Cycle)

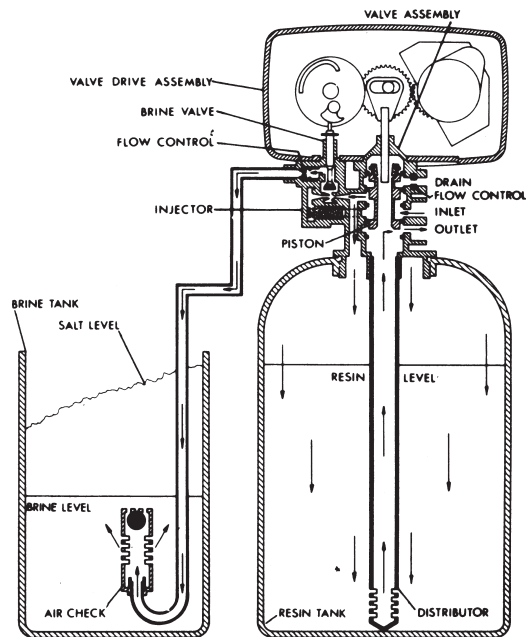

Hard water enters the unit at the valve inlet - flows around the lower piston groove - thru the injector throat - thru the brine valve and flow control to fill the brine tank. Hard water also flows around the lower piston groove - thru the passage to the top of tank - down thru the resin and enters the distributor as conditioned water. The conditioned water flows up thru the center tube to the valve outlet.

SERVICE INSTRUCTIONS

A. TO REMOVE TIME BRINE VALVE, INJECTORS, AND SCREEN

1. Unplug electrical cord from outlet.
2. Turn off water supply to conditioner:
 - a. If the conditioner installation has a "three valve" bypass system, first open the valve in the bypass line, then close the valves at the conditioner inlet and outlet.
 - b. If the conditioner has an integral bypass valve, put it in the bypass position.
 - c. If there is only a shut-off valve near the conditioner inlet, close it.
3. Relieve water pressure in the conditioner by putting the control in the backwash position momentarily. Return the control to the service position.
4. Disconnect brine tube and drain line connections at the injector body.
5. Remove the two injector body mounting screws. The injector and brine module can now be removed from the control valve. Remove and discard valve body O-rings.
6. To replace brine valve:
 - a. Pull brine valve from injector body, also remove and discard O-ring at bottom of brine valve hole.
 - b. Apply silicone lubricant to new O-ring and reinstall at bottom of brine valve hole.
 - c. Apply silicone lubricant to O-ring on new valve assembly and press into brine valve hole, shoulder on bushing should be flush with injector body.
7. To replace injectors and screen:
 - a. Remove injector cap and screen, discard O-ring. Unscrew injector nozzle and throat from injector body.
 - b. Screw in new injector throat and nozzle. Be sure they are seated tightly. Install a new screen.
 - c. Apply silicone lubricant to new O-ring and install around oval extension on injector cap.
8. Apply silicone lubricant to three new O-rings and install over three bosses on injector body.
9. Insert screws with washers through injector cap and injector. Place this assembly through hole in timer housing and into mating holes in the valve body. Tighten screws. Be sure to reinstall brass spacers with injector on Model 4600 valve.
10. Reconnect brine tube and drain line.
11. Return bypass or inlet valving to normal service position. Water pressure should now be applied to the conditioner, and any bypass line shut off.
12. Check for leaks at all seal areas. Check drain seal with the control in the backwash position.
13. Plug electrical cord into outlet.
14. Set time of day and cycle the control valve manually to ensure proper function. Make sure the control valve is returned to the service position.
15. Make sure there is enough brine in the brine tank.
16. Rotate program wheel counterclockwise until it stops at regeneration position.
17. Start regeneration cycle manually if water is hard.

B. TO REPLACE TIMER

1. Unplug electrical cord from outlet.
2. Turn off water supply to conditioner:
 - a. If the conditioner installation has a "three valve" bypass system, first open the valve in the bypass line, then close the valves at the conditioner inlet and outlet.
 - b. If the conditioner has an integral bypass valve, put it in the bypass position.
 - c. If there is only a shut-off valve near the conditioner inlet, close it.
3. Relieve water pressure in the conditioner by putting the control in the backwash position momentarily. Return the control to the service position.
4. Remove the control valve back cover.
5. Remove screw and washer at drive yoke. Remove timer mounting screws. The entire timer assembly will now lift off easily.
6. Put new timer on top of valve. Be sure drive pin on main gear engages slot in drive yoke (rotate control knob if necessary).
7. Replace timer mounting screws. Replace screw and washer at drive yoke.
8. Return bypass or inlet valving to normal service position. Water pressure should now be applied to the conditioner, and any bypass line shut off.
9. Plug electrical cord into outlet.
10. Set time of day, program wheel, and salt usage. Cycle the control valve manually to ensure proper function. Make sure the control valve is returned to the service position.
11. Replace the control valve back cover. Be sure grommet at cable hole is in place.
12. Make sure there is enough brine in the brine tank.
13. Rotate program wheel counterclockwise until it stops at regeneration position.
14. Start regeneration cycle manually if water is hard.

SERVICE INSTRUCTIONS *continued*

C. TO REPLACE PISTON ASSEMBLY

1. Unplug electrical cord from outlet.
2. Turn off water supply to conditioner:
 - a. If the conditioner installation has a "three valve" bypass system, first open the valve in the bypass line, then close the valves at the conditioner inlet and outlet.
 - b. If the conditioner has an integral bypass valve, put it in the bypass position.
 - c. If there is only a shut-off valve near the conditioner inlet, close it.
3. Relieve water pressure in the conditioner by putting the control in the backwash position momentarily. Return the control to the service position.
4. Remove the control valve back cover.
5. Remove screw and washer at drive yoke. Remove timer mounting screws. The entire timer assembly will now lift off easily. Remove end plug retainer plate.
6. Pull upward on end of piston yoke until assembly is out of valve.
7. Inspect the inside of the valve to make sure that all spacers and seals are in place, and that there is no foreign matter that would interfere with the valve operation.
8. Take new piston assembly as furnished and push piston into valve by means of the end plug. Twist yoke carefully in a clockwise direction to properly align it with drive gear. Replace end plug retainer plate.
9. Place timer on top of valve. Be sure drive pin on main gear engages slot in drive yoke. Rotate control knob if necessary.
10. Replace timer mounting screws. Replace screw and washer at drive yoke.
11. Return bypass or inlet valving to normal service position. Water pressure should now be applied to the conditioner, and any bypass line shut off.
12. Plug electrical cord into outlet.
13. Set time of day. Cycle the control valve manually to ensure proper function. Make sure the control valve is returned to the service position.
14. Replace the control valve back cover. Be sure grommet at cable hole is in place.
15. Make sure there is enough brine in the brine tank.
16. Rotate program wheel counterclockwise until it stops at regeneration position.
17. Start regeneration cycle manually if water is hard.

D. TO REPLACE SEALS AND SPACERS

1. Unplug electrical cord from outlet.
2. Turn off water supply to conditioner:
 - a. If the conditioner installation has a "three valve" bypass system, first open the valve in the bypass line, then close the valves at the conditioner inlet and outlet.
 - b. If the conditioner has an integral bypass valve, put it in the bypass position.
 - c. If there is only a shut-off valve near the conditioner inlet, close it.
3. Relieve water pressure in the conditioner by putting the control in the backwash position momentarily. Return the control to the service position.
4. Remove the control valve back cover.
5. Remove screw and washer at drive yoke. Remove timer mounting screws. The entire timer assembly will now lift off easily. Remove end plug retainer plate.
6. Pull upward on end of piston rod yoke until assembly is out of valve. Remove and replace seats and spacers with fingers.

TROUBLESHOOTING

Problem	Possible Cause	Solution
Softener fails to regenerate	Electrical service to unit has been interrupted.	Ensure permanent electrical service (check fuse, plug, pull chain or switch).
	Timer is defective.	Replace timer.
	Power failure	Reset time of day.
Softener delivers hard water	Bypass valve is open.	Close bypass valve.
	No salt in brine tank.	Add salt to brine tank and maintain salt level above water level.
	Injectors or screen plugged.	Replace injectors and screen.
	Insufficient water flowing into brine tank.	Check brine tank fill time and clean brine line flow control if plugged.
	Hot water tank hardness.	Repeated flushings of the hot water tank is required.
	Leak at distributor tube.	Make sure distributor tube is not cracked. Check O-ring and tube pilot.
	Internal valve leak.	Replace seals and spacers and/or piston.
Unit uses too much salt	Improper salt setting.	Check salt usage and salt setting.
	Excess water in brine tank.	See problem Excessive water in brine tank below.
Loss of water pressure	Iron buildup in line to water conditioner.	Clean line to water conditioner.
	Iron buildup in water conditioner.	Clean control and add resin cleaner to resin bed. Increase frequency of regeneration.
	Inlet of control plugged due to foreign material broken loose from pipes by recent work done on plumbing system.	Remove piston and clean control.
Loss of resin through drain line	Air in water system.	Ensure that well system has proper air eliminator control. Check for dry well condition.
Iron in conditioned water	Fouled resin bed.	Check backwash, brine draw and brine tank fill, increase frequency of regeneration. Increase backwash time.
Excessive water in brine tank	Plugged drain line flow control.	Clean flow control
Salt water in service line	Plugged injector system.	Clean injector and replace screen.
	Timer not cycling.	Replace timer.
	Foreign material in brine valve.	Clean or replace brine valve.
	Foreign material in brine line flow control.	Clean brine line flow control.
Softener fails to draw brine	Drain line flow control is plugged.	Clean drain line flow control.
	Injector is plugged.	Clean or replace injectors.
	Injector screen plugged.	Replace screen.
	Line pressure is too low.	Increase line pressure. Line pressure must be at least 20 psi at all times.
	Internal control leak.	Change seals and spacers and/or piston assembly.
Control cycles continuous	Faulty timer mechanism.	Replace timer.
Drain flows continuously	Foreign material in control.	Remove piston assembly and inspect bore, remove foreign material and check control in various regeneration positions.
	Internal control leak.	Replace seals and/or piston assembly.
	Control valve jammed in brine or backwash position.	Replace seals and/or piston assembly.
	Timer motor stopped or jammed.	Replace timer.

SERVICE ASSEMBLY

60102-00	Piston Assembly Cold Water - Softener
60102-10	Piston Assembly Cold Water - Feeder/Filter
60102-20	Piston Assembly, Cold Water - Low Water
60102-031	Piston Assembly - Hot Water - Softener
60102-231	Piston Assembly, 4650, 560CD CW/HW - Softener
60125	Seal Kit - Cold Water
60125-05	Seal Kit - Hot Water
60084-XXXX	Injector - Cold Water

See Parts List

***	Injector - Hot Water
60032	Brine Valve - Cold Water
60032-001	Brine Valve - Hot Water
60514	Brine Cam, 3-18
60514-01	Brine Cam, 6-36
60514-02	Brine Cam, Minutes
60510	Coupling with Clip and Screws
60040	Bypass, Brass 3/4" NPT - Cold Water
60041	Bypass, Brass 1" NPT - Hot Water
14860	Skipper Wheel - 7 Day
14381	Skipper Wheel - 12 Day

Flow Control Washers

19153	0.6 gpm
19152	0.8 gpm
19151	1.0 gpm
12085	1.2 gpm
19150	1.3 gpm
12086	1.5 gpm
19149	1.7 gpm
12087	2.0 gpm
12088	2.4 gpm
12089	3.0 gpm
12090	3.5 gpm
12091	4.0 gpm
19147	4.5 gpm
12092	5.0 gpm
17814	6.0 gpm
12408	7.0 gpm

***Hot water injector components are listed separately.

